

Sattelzugmaschinen / Tracteurs / Tractors

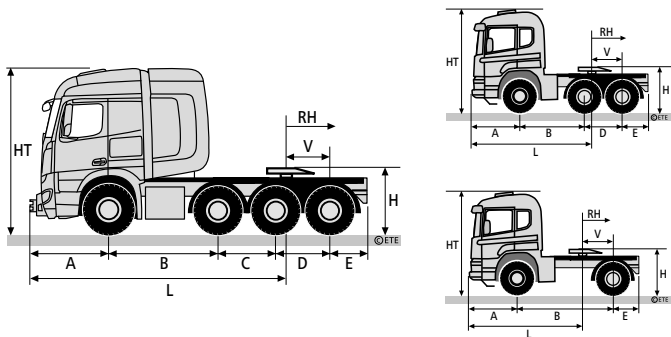

EMIL EGGER	I	L	V	A	B	C	D	E	HT	H	RH	GG	GG	L**	V**
		[cm]	[cm]	[cm]	[cm]	[cm]	[cm]	[cm]	[cm]	[cm]	[cm]	[t]	[t]	[cm]	[cm]
44	4x2	450	57	136	370	-	-	82	400	100	174	7.8	18	-	-
48	4x2	450	60	140	370	-	-	105	376	92	182	8.2	18	-	-
340	4x2	450	38	136	350	-	-	80	365	115	163	7.7	18	-	-
344	4x2	454	61	145	370	-	-	84	331	112	182	7.2	18	-	-
350	4x2	450	60	140	370	-	-	105	389	94	182	8.3	18	-	↑121
378	4x2	450	58	147	360	-	-	80	390	107	186	7.9	18	-	-
601	4x2	450	52	141	361	-	-	104	360	111	186	7.5	18	-	-
257*	4x4	450	60	150	360	-	-	85	336	125	183	8.4	18	-	-
373	4x4	450	58	147	360	-	-	80	350	111	188	7.8	18	-	-
379	4x4	449	58	147	360	-	-	80	352	114	186	8.0	18	-	-
346	6x4*	453	111	136	290	-	137	102	382	121	232	10.1	32	-	-
351*	6x4*	453	111	136	290	-	137	102	382	121	232	10.2	32	-	-
352*	6x4	455	115	141	295	-	135	100	384	114	225	9.9	33	-	-
354	6x4	453	117	145	290	-	135	93	363	114	226	9.8	33	453	117
357*	6x4*	492	124	149	320	-	137	99	378	125	227	10.8	33	-	-
359	6x4	452	123	136	300	-	137	90	365	114	227	9.7	29	472	102
361	6x4	449	114	136	290	-	137	99	375	114	223	9.9	32	449	114
364	6x4	452	122	136	300	-	137	99	375	114	230	9.9	31	472	102
367*	6x4*	448	122	136	300	-	137	102	380	115	231	10.1	32	468	102
383	6x4	450	122	136	300	-	137	90	372	114	227	9.6	29	472	102
603	6x4	455	120	145	290	-	137	93	370	114	226	9.8	29	461	119
850	6x4	452	135	149	310	-	140	70	365	119	145	10.4	29	-	-
851	6x4	510	80	145	310	-	135	80	365	117	226	9.8	29	-	-
338*	8x4*	520	134	150	238	132	137	105	386	128	252	13.9	42	-	-
345*	8x4*	548	127	150	248	142	135	80	386	128	240	13.0	42	-	-
376*	8x4*	480	145	160	188	142	135	100	391	129	260	13.9	42	-	-
353*	8x6*	535	157	175	180	200	135	109	400	146	275	16.9	43	-	-
362*	8x6*	597	125	175	285	135	135	100	400	135	240	16.5	42	647	75
363*	8x6*	527	159	161	187	187	138	100	398	132	264	15.5	41	575	109

48 ≤ 127 338* ≤ 339* 354 ≤ 349 ≤ 606 GG @ 80 km/h
 340 ≤ 256 ≤ 255 357* ≤ 356* *Crawler / WSK / TRK
 346 ≤ 348 ≤ 608 ≤ 377 ≤ 343 361 ≤ 602 ≤ 375 ≤ 374 *Hydraulik ab SZM
 351* ≤ 347* ≤ 368* ≤ 370* ≤ 371* ≤ 607* ≤ 342* ≤ 341* 367* ≤ 365
 352* ≤ 335* ≤ 360* ≤ 369* ≤ 600* ≤ 852* ≤ 337* ≤ 699* 603 ≤ 604 ≤ 605 ≤ 372