

**EGGER ESK 30**

**314, 326**

	max. 16,5 m		2 x 12 t = 24 t		4 x 4	
	max. 30,0 m		5 km/h		4 x 4	

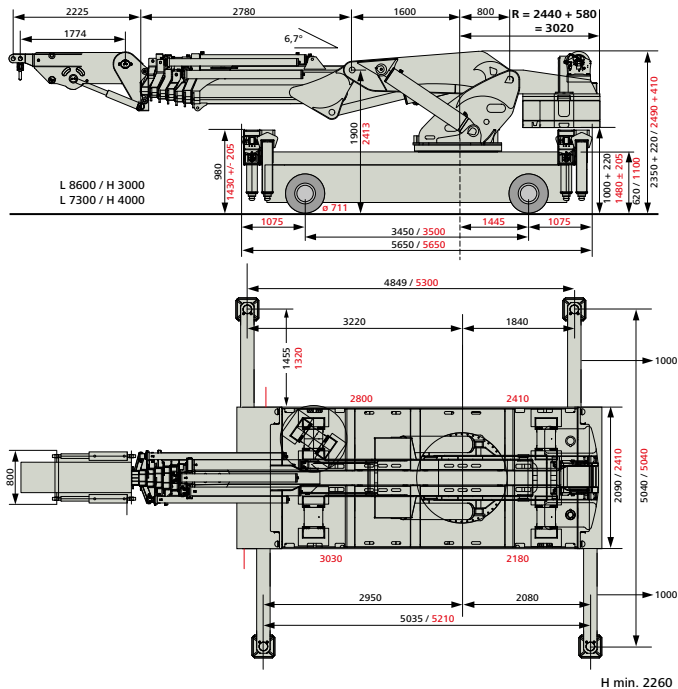

Weitere Ausrüstungen auf Anfrage, z.B. Rotatorkopf, Wand-Elementmontageplatte, etc.  
D'autres équipements sur demande, par ex. tête rotative, plaque de montage pour éléments de façade.  
Further special equipment on request, e.g. rotating head, element wall assembly plate, etc.

--	--	--	--	--	--	--

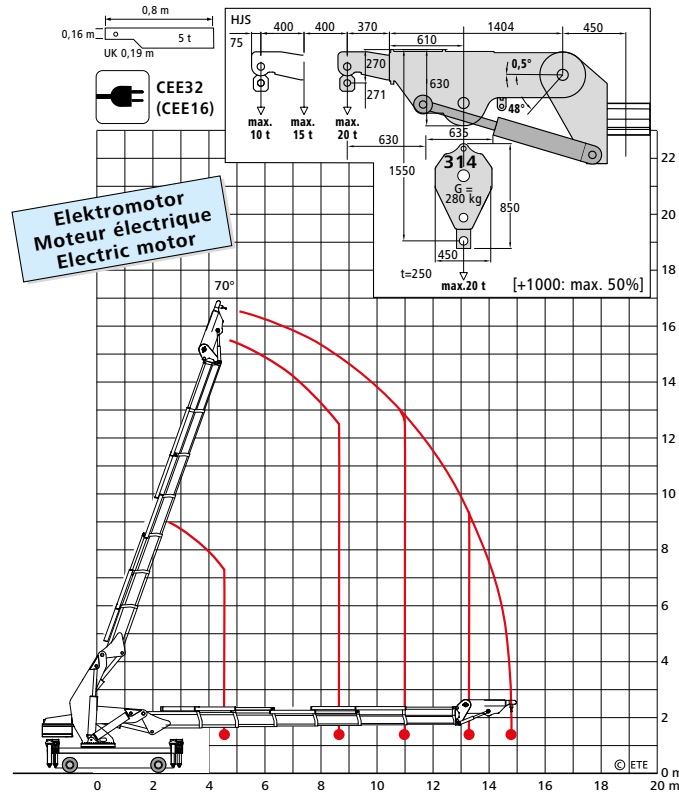

<b>8 t</b>	R=2,44 m	23.8	20.0	14.0	10.0	7.0	5.4	4.8 t
		4.6	5.5	6.5	8.8	11.0	13.2	14.5 m





**EGGER ESK 30**



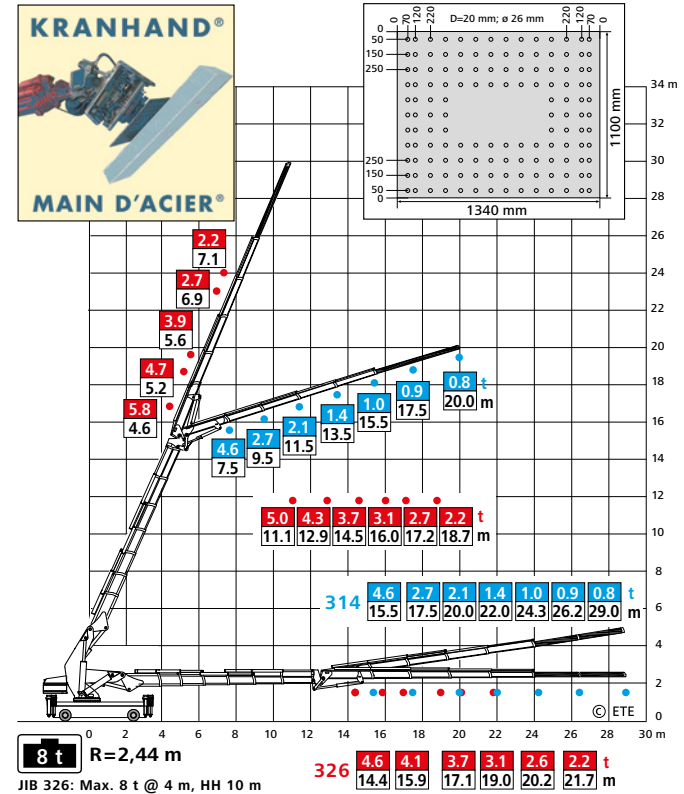

**Zubehör ESK / Accessoire ESK / Accessories ESK**

Mit den Egger-Spezial-Kranen (ESK) findet sich dank umfangreichem Zubehör für jede Hebe- und Montageaufgabe die optimale Lösung.

*Avec les grues spéciales Egger (ESK), il est possible de trouver la solution optimale pour chaque tâche de levage et de montage grâce à une gamme complète d'accessoires.*

The Egger Special Cranes (ESK) offer the optimum solution for every lifting and assembly task thanks to a comprehensive range of accessories.



ESK 30:  $\curvearrowright$  2.5 t @ 0.9 m, h = 650 mm;  $\dashrightarrow$  5 t @ 0.78 m, h = 243 mm;  $\dashrightarrow$  2.5 t @ 3.28 m, h = 243 mm; 25 t Montagebock  
 ESK 75: 5 t Montageplatte

